

Lasiris™ Green PowerLine Laser

INSTRUCTION MANUAL

Version 1

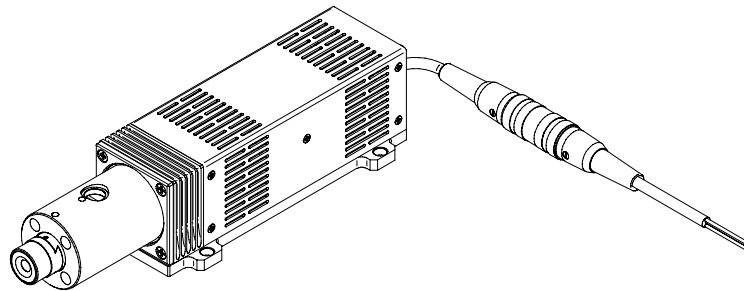

Updated: April 2009

STKR # 990-0021



CAUTION NOTE

PLEASE READ THE ENTIRE MANUAL BEFORE ATTEMPTING TO OPERATE YOUR LASER. **OPERATING LASIRIS LASERS USING PROCEDURES OTHER THAN THOSE SPECIFIED HEREIN MAY RESULT IN HAZARDOUS RADIATION EXPOSURE.**

AVOID EXPOSURE TO DIRECT OR SCATTERED RADIATION FROM THE LASER.

It is extremely important to follow laser safety rules and wear appropriate protective eyewear when working around these lasers. As a general rule, you should avoid eye or skin exposure to direct or scattered radiation from these lasers.

All laser safety-warning labels are provided on the Unit and comply with 21 CFR 1040.10 pursuant to the radiation control for the health and safety act of 1968.

All Lasiris lasers are in full compliance with the United States CDRH and the European IEC 60825-1 laser Safety Regulations.

CAUTION- Use of controls or adjustments or performance of procedures other than those specified herein may result in hazardous radiation exposure.

Please read and follow all WARNING statements throughout this manual.

Table of Contents

1. STOCKERYALE’S LASIRIS™ PRODUCTS.....	1
2. INCOMING INSPECTION	1
3. LASER OPERATION.....	2
3.1 SET-UP.....	2
3.2 TURNING THE LASER ON.....	4
3.3 TURNING THE LASER OFF	4
3.4 MODULATING THE LASER.....	4
3.5 MAXIMUM OUTPUT POWER ADJUSTMENT.....	5
3.6 OPERATING ENVIRONMENT	5
3.7 INSTALLATION.....	5
3.8 OPTICS AND FOCUSING	6
4. CLEANING THE OPTICS	7
5. OPERATING HINTS.....	7
6. SAFETY.....	8
6.1 PROTECTING DEVICES	8
6.2 SAFETY KEY BOX WITH REMOTE INTERLOCK FOR CLASS IIIB LASERS	9
6.3 LASER SAFETY & CLASSIFICATION.....	9
6.3.1 CLASSIFICATION	9
6.3.2 CDRH CLASSIFICATION	11
6.3.3 IEC CLASSIFICATION	12
6.3.4 CLASSIFICATION REQUIREMENTS	12
7. PRODUCT WARRANTY AND REPAIR	14
7.1 PRODUCT WARRANTY	14
7.2 PRODUCT REPAIR	14
RETURN MERCHANDISE AUTHORIZATION CARD.....	15
APPENDIX A – GREEN POWERLINE SPECIFICATIONS	16
APPENDIX-B – MONITORING OF DIODE TEMPERATURE.....	19

VISIT OUR WEBSITE (FAQS) FOR THE LATEST VERSION OF THIS MANUAL:
<http://www.stockeryale.com/lasers/>

1. StockerYale's Lasiris™ Products

Your Lasiris product is the result of extensive research and development, and customer feedback. All instructions should be read prior to operating the laser to ensure its proper functioning, and, more importantly, to ensure the safety of its users.

Lasiris Green PowerLine lasers feature high quality glass optics, a rugged housing, and a thermo-electric cooler to maximize the laser's reliability. For insured longer lifetime, all diode lasers have undergone an extensive burn-in period and a final quality control check before shipment.



Should you have any comments or suggestions regarding a StockerYale product or service, please do not hesitate to contact us. We can be reached at (514) 685-1005, or at 1-800-814-9552, or by fax at (514) 685-3307.

Thank you for your support!

2. Incoming Inspection

Immediately upon receipt of your product, examine the packaging material and contents for shipment damage. Report any such instance to your receiving department or shipping company.

Your shipment should contain the following items:

<ul style="list-style-type: none"> ➤ (1) one laser unit 	<ul style="list-style-type: none"> ➤ Upon demand, (1) one power supply, 115 or 220 VAC 
<ul style="list-style-type: none"> ➤ (1) one Allen wrench (0.035 in) – for lens removal ➤ (1) one Allen wrench (0.050 in) – for focus lock (SSC 4/40) 	<ul style="list-style-type: none"> ➤ For Class IIIb, lasers only (if ordered): (1) one key box with (2) two keys and (1) one 1/8" mini-plug  <p style="text-align: right;"><i>Part No.: M-1.5</i></p>

In the event that any of these items are missing, please contact your StockerYale representative immediately, or contact directly the laser division of StockerYale by calling (514) 685-1005 or 1-800-814-9552. Please have your product invoice information available.

3. Laser Operation

WARNING!

The output power of these laser devices are sometimes high enough to cause permanent damage to the human eye. You should wear appropriate laser safety goggles at all times when the laser is operational.

Do not place any flammable objects directly in front of the free, non-extended beam (without the line generating optics), especially with higher power beams.

3.1 Set-up

❖ **STANDARD LASER** ❖

The standard laser comes with a two-lead wire for the power supply and a male DB9 connector for monitoring and modulation.

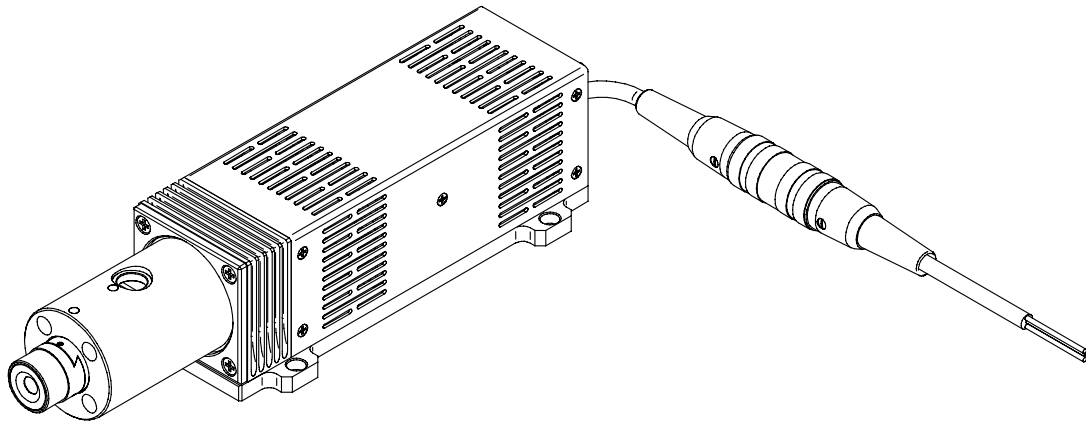

White (pos.) - Black (neg.) → Power supply 5 VDC \pm 0.5 VDC
Provide at least 3A for startup and operation
(4A for extreme operation)

Back Panel of the Lasiris Green PowerLine laser

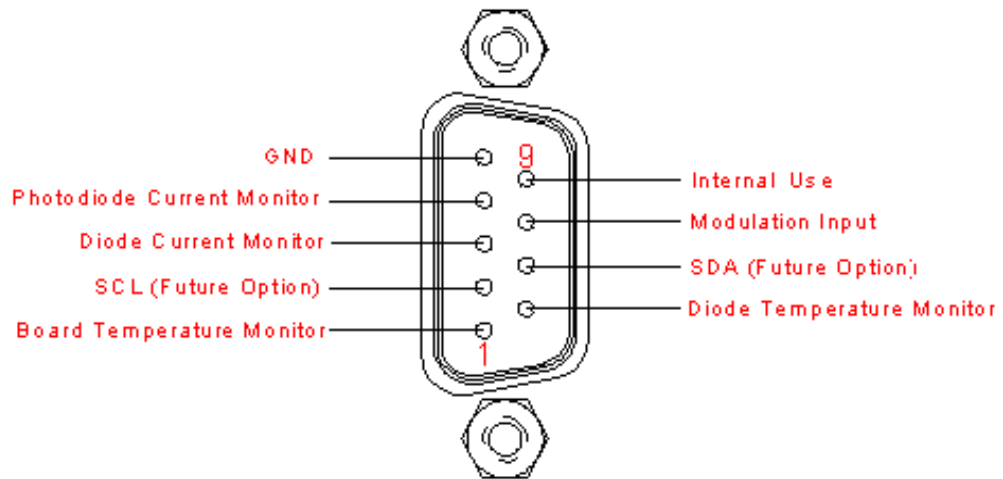
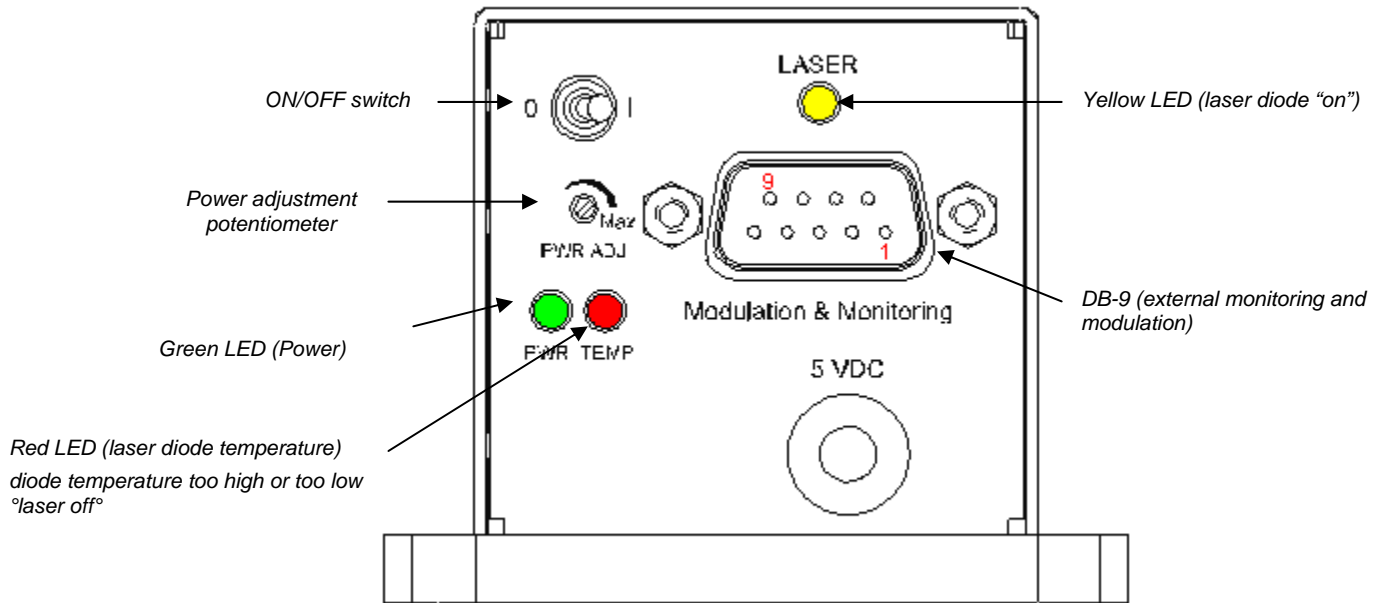

Diode current (mA) = diode current monitor (mV)

Power (mW) = Photodiode current monitor (mV)

3.2 Turning the Laser ON

Once the laser is properly plugged in,

- Plug/Turn the Power Supply ON.
- Turn the Main Switch of the laser ON (at the back of the laser). The green LED (Power "on") at the back of the laser will light up.
- After a few seconds (in normal ambient temperature), the laser will turn ON. The laser's thermoelectric cooling device (TEC) maintains the diode at 25°C. The laser will not turn ON until the diode temperature stabilizes at 25°C. If the temperature largely exceeds ambient conditions, the red LED will be lit, and the laser will not turn ON. Moreover, **you must wait 2-3 minutes after the laser is turned ON before obtaining stable power output.**
- Remember to not obstruct the ventilation on the sides and at the back of the laser.

3.3 Turning the Laser OFF

Follow these instructions to turn the laser off:

- Turn the Main Switch OFF.
- Unplug/Turn the Power Supply OFF.

3.4 Modulating the Laser

The Modulation mode allows the user to control the output power intensity of the laser or to freeze an object's motion for image capture by strobing the light source. Follow the instructions in section 3.1 to properly connect the laser to either CW (Continuous Wave) mode or Modulation mode. The modulation source is connected to the DB9 connector.

You can modulate the laser in one of *two modes*:

3.4.1 Standard Mode: Linear modulation

The modulation source is a variable amplitude signal. It can be a pulsed or an analog signal.

Input voltage 0V means laser ON (maximum power)

Input voltage 5V means laser OFF.

3.4.2 Optional Mode: Reverse linear modulation

Input voltage 0V means laser OFF (maximum power)

Input voltage 5V means laser ON (maximum power)

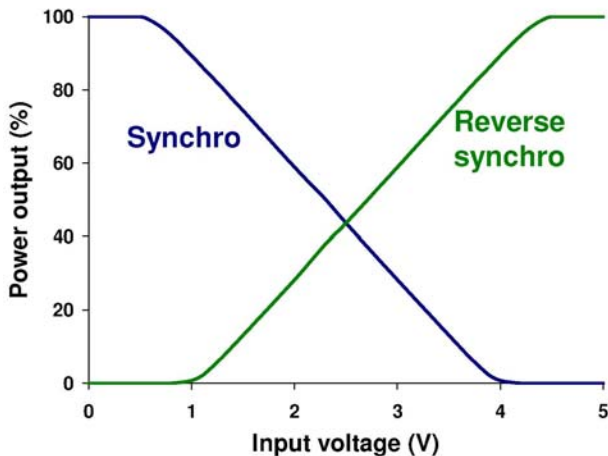

NOTE: Curves can vary depending on model.

In these two modes, the maximum frequency of the pulsed modulation (linear or reverse) is 100Hz. The fall time and rise time are less than 1 ms.

3.5 Maximum Output Power Adjustment

You can limit the maximum output power level of your Green PowerLine laser. The limit has been set at the maximum value at the factory. If you want to limit the power to a lesser value, use a small, flat screwdriver to reduce the upper limit of the output power by turning the power adjustment potentiometer (on the back of the laser) counterclockwise. To return the power to its original setting, turn the potentiometer clockwise to its maximum position (there are a total of 11 turns). You cannot bring the output power above the factory-set limit.

3.6 Operating Environment

The Green PowerLine laser will operate from -20°C to $+45^{\circ}\text{C}$. It is not recommended to operate the laser outside of this temperature range for prolonged periods. The unit is designed to shut down if the laser becomes too hot or too cold. During this time, the red LED (diode temperature) will light up until the diode temperature returns to approximately 25°C . Once the laser stabilizes at its normal operating temperature, the red LED (diode temperature) will shut off and the laser will light up.

As with all semiconductor materials, avoid prolonged or repeated exposure to electrostatic charges or water. All Lasiris lasers are designed with ESD protection.

Our lasers are suitable for indoor and outdoor use and function normally when the following environmental conditions are met:

- Altitudes of up to 2000 m, and
- Environments where the maximum relative humidity (RH) is 80% (for temperatures up to 31°C). Note that above 31°C , the RH decreases linearly from 80% to 50% (at 40°C).

3.7 Installation

Mounting the laser

StockerYale suggests that the laser be mounted on a flat, thermally dissipating surface to maintain a high-level of pointing stability, heat dissipation, and reliability. All Green PowerLine

lasers were tested on a non-thermally conductive surface to represent a “worst case scenario”. There are two holes on each side of the base to secure the laser. Those holes are designed for #6 Socket Head Cap Screws.

Ventilation

The ventilation holes should not be obstructed to ensure proper ventilation of your Green PowerLine laser. In addition, the laser should be operated in an environment in which there is normal aeration.

3.8 Optics and Focusing

Users can easily focus the Green PowerLine laser for a specific range. However, please remember to use caution around all laser products. Lasers are highly concentrated light sources, some invisible to the eye. As a general rule, use caution when working on or near any laser product. Never point a laser beam into your or any other person’s eyes; permanent damage to the retina can occur!

WARNING!

Due to our patented optical design, most of our visible laser products are CDRH classified as Class II and IIIa products, meeting this classification only as complete assemblies (see section 6). Removal of the pattern generation optics for focusing and/or cleaning could expose personnel to hazardous laser radiation and will void the product safety class. Turn the laser OFF whenever the optical head is removed, unless alignment is being performed, in which case you must use extreme caution. Never look directly at a raw laser beam. StockerYale will not be held liable for any injuries caused by product misuse.

NOTE: If you have a specific application in which the accuracy of the focusing is important and you would like us to pre-focus the laser utilizing a sophisticated beam profiler, please contact your sales representative or StockerYale (514-685-1005 or 1-800-814-9552) for details.

Follow Steps 1 through 3 for external focusing

- 1) Turn the laser ON.
- 2) Turn the focus adjusting screw (located on the body of the laser) using a flat head screwdriver. If needed, loosen the set-screw (SSS 4/40) a few turns. This will release the pressure on the focusing assembly, allowing the collimator to slide freely.

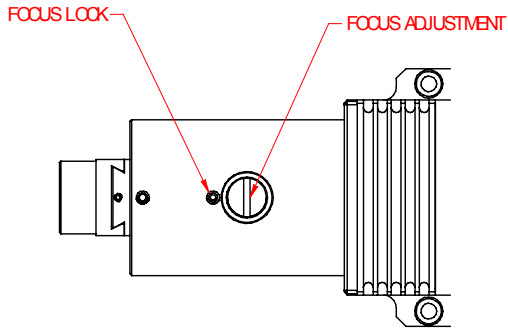

- 3) After focus adjustment, re-tighten the SSS 4/40 screw to lock the focus.
Your image should now be in focus at the required target distance.

4. Cleaning the Optics

Our laser should provide you with years of reliable service. Should the actual dot or image become fuzzy or unclear, please verify the following:

- 1) Confirm if the image is in focus (if not, follow instructions in Optics and Focusing section).
- 2) Verify if the optics have been contaminated.

If the optics have become contaminated, it is best to try and remove visible contamination by blowing dry air across the surface. Make sure the air product is oil- and moisture-free. If this technique fails to remove the contaminants, gently wipe the glass surface with a piece of slightly damp lens tissue. We recommend a water-based mild detergent or a glass cleaner (e.g., Windex) to be applied to the tissue. **Please attempt the process only after non-contact methods have failed.** Some of our optics have a special Anti-Reflective Coating. Using a cleanser (such as isopropyl alcohol) to remove contamination could **damage** this coating and the optical lens assemblies.

If your laser generates a pattern requiring a **diffraction grating**, only use a jet of nitrogen or air to clean the surface of the grating. Using other products will damage the grating.

5. Operating hints

A broad line or band of light can be projected (line-generating lasers only) by slightly de-focusing the laser source (follow Optics and Focusing section, but try to *enlarge* the image spot at your desired target distance). The larger the dot area at focus, the dimmer the overall light pattern will be. Try to determine the best focused spot size for your band of light application.

The angle of illumination and detection can greatly enhance a characteristic or defect you may be trying to capture. If physical parameters allow, try optimizing the camera or detector position versus the laser position. See the examples below.

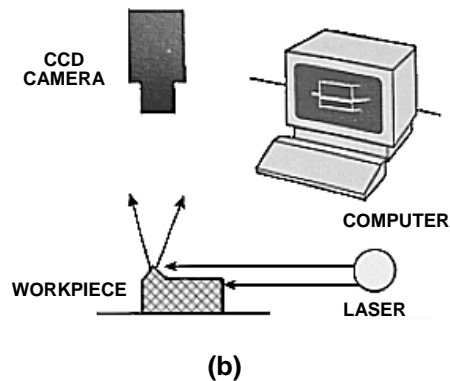
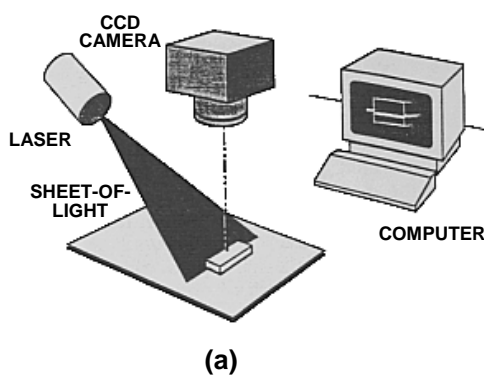

- (a) A laser at a steep angle can be useful for edge, trim and insertion detection.
- (b) A laser mounted at a low angle will tend to highlight surface topography and edge characteristics. This has proven to be useful in such applications as semiconductor orientation systems or magazine and newspaper counting systems. As the material moves by, the lines are bent by the edges and a vision system counts the bent line shapes.

6. Safety

StockerYale takes great care in making sure your laser is in full compliance with the United States CDRH, European EN60825-1, and IEC 60825-1 laser safety requirements. Several safety features have been developed for the proper use of our laser products:

WARNING!

Use of controls, adjustments or performance of procedures other than those specified herein may result in Hazardous Radiation Exposure and will void the product warranty.

The laser light emitted by this unit may be in the Infrared area of the electromagnetic spectrum. The laser light may not be visible to the human eye. Use extreme caution at all times when laser is in use.

The output power of this laser device is high enough to cause permanent damage to the human eye. You should wear appropriate laser safety goggles at all times when the laser is operational.

6.1 Protecting Devices

There are two types of protecting devices for your laser:

1. Cap: The red vinyl cap serves to protect the laser during storage or inactivity. To use it, slide the cap onto the laser face. Do not use the cap to block laser light since the heated plastic could contaminate the optics.



Red vinyl cap

2. ON/OFF switch: The On/Off toggle switch is located at the back of the laser. If the laser operation is not required for your assembly procedures, switch the laser to the OFF position to protect personnel from accidental beam exposure. The laser can be re-activated by switching the toggle switch to the ON position.

6.2 Safety Key Box with Remote Interlock for Class IIIb Lasers

To obtain classification, Class IIIb and Class IV lasers require the installation of a safety mechanism preventing exposure to the laser light. As such, if your laser is Class IIIb compliant, it may come equipped with a safety key box.



Safety interlock key box

The key box is essentially an interlock circuit that must be closed for the laser to operate, i.e., it must have the shorted 1/8" jack plugged into it and the key switched to ON. This means that you can use the Interlock connector two ways.

- (1) **For General Use:** Plug the shorted jack into the key box and switch the key to ON for normal laser operation. After a short delay, light will be emitted from the laser, provided that the toggle switch on the laser is also in the ON position. The laser will automatically shut off if the shorted jack is not in place.
- (2) **For Interlock System:** When the Interlock circuit is opened, the laser will automatically shut off. For example, you can connect the two wires of the 1/8" interlock plug to a door contact switch (remove the cover and solder from the interlock plug, then re-solder twin leads to appropriate pins, and replace the cover). Whenever the door is opened, thus opening the Interlock circuit, the laser will turn off automatically.

6.3 Laser Safety & Classification

6.3.1 Classification

Lasers are classified according to the output power and the wavelength of a laser beam in a particular setup according to the United States Center for Devices & Radiological Health (CDRH) document 21 CFR 1040.10, and, upon demand, to the International Electrotechnical Commission (IEC) document 60825-1:2nd edition, 2007-03. The protocol for classification described herein is a general outline of the procedures. In actual practice, the settings can differ depending on the laser. Call us for details.

The laser beam (either as a raw or modified beam) is aimed into a 7 mm aperture located some distance away from the laser. The detector placed just behind the aperture records the *highest* output power level of the laser beam. See the table below for details. In the case of a line laser, the entire line is scanned to find the highest output power.

With conventional Gaussian line generators, it is generally the hot central spot that causes its safety rating to go up one class (e.g., from CDRH Class II to IIIa). Our patented optics produce a line of uniform intensity that does not have a hot spot at the center. Therefore, a Lasiris non-Gaussian laser can offer a safer level of exposure, in addition to more light and uniform illumination transmitted to your part.

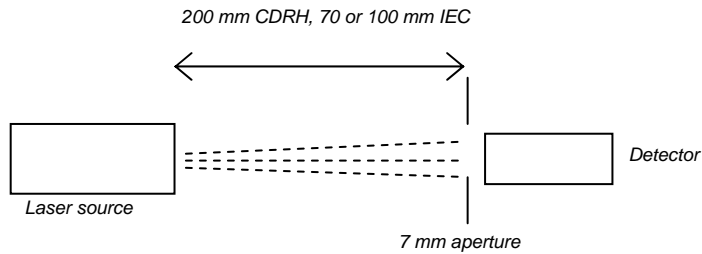

Setup for CDRH and IEC classification

Organization	Class	Wavelength	Maximum Power* some distance away from the laser source	Distance between laser source and detector measuring power
CDRH	II	400-710 nm	1 mW	200 mm
	IIIa	400-710 nm	5 mW	200 mm
	IIIb	400-710 nm	500 mW	200 mm
		or >710 nm	500 mW	200 mm
IEC	1	500-700 nm	0.39 mW	70 mm
	1M	500-700 nm	0.39 mW	100 mm
	2	400-700 nm	1 mW	70 mm
	2M	400-700 nm	1 mW	100 mm
	3R	400-700 nm	5 mW	70 mm
	3B	400-700 nm	500 mW	70 mm

Possible CDRH and IEC classifications for Lasiris lasers.

*For the IEC, wavelengths outside of those stated have different maximum power values.

**CDRH – between laser aperture and detector; IEC – between apparent focal point and detector. Call for details.

Generally speaking, the higher the safety class your laser is given, the higher becomes the risk of eye injury. As a precaution, it is always advisable to wear appropriate safety goggles to protect your eyes from harmful radiation. And, even for “eye-safe” classes, the laser beam should never be intentionally aimed at people.

- CDRH Class II

- IEC Class 1 and Class 2

Considered eye-safe, including while using optical instruments for intrabeam viewing. Normal exposure to this type of beam will not cause permanent damage to the retina, since the blinking reflex of the human eye is fast enough to avoid any damage. This safety rating is considered eye-safe, but can be hazardous if there is direct long-term ocular exposure. Lasers with this rating can be installed on the shop floor with a minimum of concerns.

- CDRH Class IIIa

- IEC Class 1M, Class 2M, and Class 3R

Considered eye-safe with caution, but may present an eye hazard if viewed using collecting optics (magnifiers, binoculars, etc.). Focusing of this light into the eye could cause eye damage.

- CDRH Class IIIb

- IEC Class 3B

Considered dangerous to your retina if exposed, including exposure when looking directly into a reflection from a specular (mirror-like) surface. Normally, lasers from this class will not produce a hazardous diffuse reflection. At higher levels of the class, these lasers can be skin hazards. It is

important to follow laser safety rules and **wear appropriate protective eyewear** when working around these lasers.

The following directives are taken from section 12.5.2 of IEC 60825-1, and are good safety measures for both CDRH Class IIIb and IEC Class 3B lasers:

Class 3B lasers are potentially hazardous if a direct beam or specular reflection is viewed by the unprotected eye (intrabeam viewing). The following precautions should be taken to avoid direct beam viewing and to control specular reflections.

- a) The laser should only be operated in a controlled area.
- b) Care should be exercised to prevent unintentional specular reflections.
- c) The laser beam should be terminated where possible at the end of its useful path by a material that is diffuse and of such a color and reflectivity as to make beam positioning possible while still minimizing the reflection hazards.

NOTE: Conditions for safe viewing of diffuse reflections for Class 3B visible lasers are: minimum viewing distance of 13 cm between screen and cornea and a maximum viewing time of 10 sec. Other viewing conditions require a comparison of the diffuse reflection exposure with the MPE (maximum permissible exposure limit).

- d) **Eye protection is required** if there is any possibility of viewing either the direct or specularly reflected beam, or of viewing a diffuse reflection not complying with the conditions of item c).
- e) The entrance to areas should be posted with a standard laser warning sign.

6.3.2 CDRH Classification

Our lasers can comply with CDRH classification and fall in different safety classes depending on output power, wavelength and fan angle.

CDRH Class II, IIIa, and IIIb Warning / ID / Aperture Labels

Statement indicating that the laser light is emitted from the aperture. Warning statement follows.

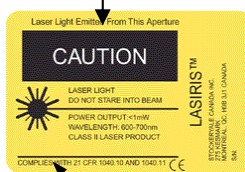

Statement confirming whether or not the laser product is CDRH compliant, printed on the bottom of the stickers.

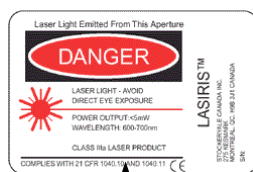

CDRH laser class is located here.

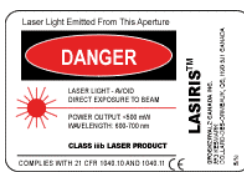

Power output and wavelength details are located here.

Trademark, date, company address, serial number, and electronic option code are printed on the right side of all of our stickers.

6.3.3 IEC Classification

Our lasers can comply with IEC classification (please mention it at the time of order if it is required) and fall in different safety classes depending on output power, wavelength and fan angle.

IEC Warning / ID / Aperture Label Example

IEC laser class and statement confirming that the user should avoid exposure to beam.



6.3.4 Classification Requirements

Classification is obtained once the laser meets the criteria established by the CDRH or the IEC. Although Lasiris lasers come standard with CDRH compliance, some custom-made lasers may not comply with all of the safety requirements. However, lasers are always classified into a safety class, i.e., CDRH Class II, IIIa, IIIb, and IEC Class 1, 1M, 2, 2M, 3R, 3B. **Lasers do not need to be fully compliant unless the end-user requires it to be so. Please mention it at the time of order.**

CDRH Requirements

Class II and IIIa

1. laser radiation emission indicator (LED turning on when laser is powered)
2. beam attenuator (a cap)
3. warning / identification / aperture label (see images above)
4. instruction manual

Class IIIb

1. all items mentioned for Class II and IIIa lasers
2. removable key-actuated master control preventing lasing when removed
3. remote interlock connector that prevents lasing when removed
4. laser radiation emission indicator that turns on prior to lasing (LED that lights up 5-10 seconds before the laser lights up)
5. ON/OFF switch (although this feature is also standard on our Class II & IIIa lasers)

A special key box can be ordered to fulfill criteria 2, 3, and 4. See section 6.2 for details.

IEC Requirements

Class 1, 1M, 2, 2M

1. warning/ID/Aperture label affixed (sticker on the laser with all the required information – see above)
2. instruction manual

Class 3R

1. all items mentioned for Class 1, 1M, 2, 2M lasers
2. laser radiation emission indicator (LED turning on when laser is powered) for lasers >700 nm
3. beam attenuator (a shutter)

Class 3B and 4

1. all items mentioned for Class 3R lasers
2. laser radiation emission indicator, regardless of wavelength
3. removable key-actuated master control preventing lasing when removed
4. remote interlock connector that prevents lasing above Class 1M or 2M when removed
5. manual reset mechanism for class 4

A special key box can be ordered to fulfill criteria 3 and 4. See section 6.2 for details.

7. Product Warranty and Repair

7.1 Product Warranty

The Green PowerLine laser is guaranteed to be free from material & manufacturing defects for a period **one (1) year** from the date of shipment, except for the laser diode that is covered for a period of **six (6) months**. Should a product fail during this period, StockerYale will, at its discretion, repair or replace the damaged unit. Repaired or replacement units will be covered for the remainder of the original equipment warranty period. The warranty does not apply to the units examined by StockerYale that are found to have failed due to abuse, acts of nature, mishandling, alteration, improper installation or negligence.

7.2 Product Repair

Each Lasiris laser has been designed to exhibit proper mechanical and temperature stability. As such, no user serviceable parts are located inside the laser. **Please do not attempt to take the assembly apart. Any such action will void the product warranty.**

In the event that you should experience a product failure, there are four steps to take when you return a unit for repair. (Customers who purchase StockerYale products through a distributor will need to contact them directly for details on how to return a defective product.)

1. Obtain a Return Merchandise Authorization number (RMA #) by calling us. Please contact the factory at 1-800-814-9552 or at (514) 685-1005 during regular business hours, between 9:00 a.m. and 5:00 p.m. (17:00) EST for an RMA number. This number is necessary to track your product repair accurately and efficiently. Once you have been issued an RMA number, please make sure it appears on any packing material sent with the laser, including on the outside of your shipping container.
2. Fill in the RMA card (found on the next page).
3. Pack the unit properly with the RMA label. The unit should not be able to move around in the box. Using the RMA label provided on the next page, affix the RMA label to the top of the parcel.
4. Ship the unit to the correct address. Ship to:
StockerYale Canada
275 Kesmark
Montreal, Quebec
H9B 3J1
CANADA

The clearance through customs (both in and out of Canada) will be arranged by StockerYale.

*****IMPORTANT***** Please note that all parcels originating from outside of Canada must include a declaration for customs with the following information:

- Full description of contents
- Quantity
- Unit Price (Typically \$20-\$30 for custom purposes only)
- Total Value
- And the following statement: *Goods of Canadian Origin being returned for repair; value for custom purpose only*

Return Merchandise Authorization Card

Ship to: StockerYale Canada Inc.
275 Kesmark
Montreal, Quebec
Canada H9B 3J1

Type of unit returned: Lasers Phase Masks Diffracting Optics Other

Serial # _____

REPORTED MALFUNCTION: _____

FROM: _____
ADDRESS: _____

CITY / STATE: _____ **ZIP:** _____

RMA #

Please cut on dotted line and affix to package

IMPORTANT: Please note that all parcels originating from outside of Canada must include a declaration for customs with the following information:

- Full description of contents
- Quantity
- Unit Price (original value)
- Total Value
- And the following statement:
**Goods of Canadian Origin being returned for repair;
value for custom purposes only**

Appendix A – Green PowerLine Specifications

FOR TECHNICAL SPECIFICATIONS AND MECHANICAL DIAGRAMS, PLEASE VISIT OUR WEBSITE FOR THE MOST UP-TO-DATE GREEN POWERLINE DATASHEET:

<http://www.stockeryale.com/lasers/>

Optical & Environmental specifications

- Power: 100, 150, 200 mW
- Wavelength: 532 nm
- Intensity distribution: Uniform (non-Gaussian) lengthwise, Gaussian widthwise
- Standard Fan angles: 10°, 15°, 20°, 30°, 40°, 45°, 55°, 60°, 75°
- Line thickness (focus): User adjustable
- Bore sighting: <3 mrad (collimated)
- Wavelength drift: Maximum ± 1 nm over entire operating temperature range
- Operating temperature: -20°C to +45°C
- Storage temperature: -40°C to +70°C

Electrical specifications

- Power supply voltage: 5 VDC \pm 0.5 VDC
- Power supply current: 3 A at ambient temperature, 4 A maximum.
- Built-in protections: Entire product: ESD, over-voltage up to 12V, reverse polarity of power supply. Laser diode: over-heating, over-current
- Laser diode operating temperature: 25° C \pm 0.5° C (adjusted in factory)
- Max. beam power: User adjustable (trim potentiometer on the back panel)
- Beam modulation: External, through a DB-9 connector on the back panel
- Monitoring: Laser temperature, Laser current, PD current, through the DB-9 connector

Modulation Options

- Standard (option S):
Input voltage 0V means laser ON (maximum power)
Input voltage 5V means laser OFF.
- Reverse (option RS):
Input voltage 0V means laser OFF (maximum power)
Input voltage 5V means laser ON (maximum power)

Pulsed modulation available for both options

- Maximum frequency : 100 Hz
- Rise / Fall time: \leq 1ms

Appendix B

Temperature Monitor (V) versus Diode Temperature ($^{\circ}\text{C}$)

